MINIPIX

Datasheet

Model No.: MNXTXE-XPx200421



General features

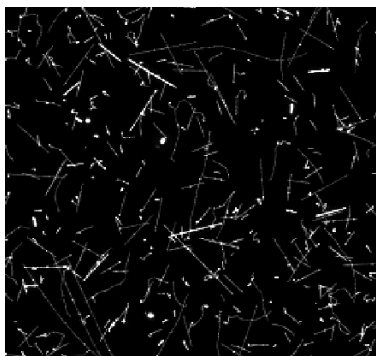

Illustration of single particle sensitivity of Timepix3 device. The tracks of different particles of radiation background (mostly muons and few protons) were recorded in 5 minutes on board of airplane. No noise (clean zero) is seen in dark regions.

The **MINIPIX** is miniaturized and low power solution of radiation camera with single particle counting (or particle tracking) detector Timepix. The standard **MINIPIX** system incorporates single Timepix detector (256 x 256 pixels with pitch of 55 μm) with sensor according to customer preference (standardly 300 μm thick silicon). It uses USB 2.0 interface capable to read up to 45 frames per second (with exposure time of 1 ms). The Timepix detector is energy sensitive which brings a new dimension to radiographic images.

The **MINIPIX** device is controlled via USB interface. The major operating systems are supported (MS Windows, Mac OS and LINUX). The complex software PIXET PRO used for detector operation is provided for free.

Several **MINIPIX** devices connected to single or several computers can be operated together forming the radiation monitoring network. The whole group is accessed using advanced application allowing setting of alarm levels for different radiation types, performing data logging and calculating various statistics, protocols and charts. Such network can serve as long time monitor of environment¹. Several other devices developed in IEAP CTU in Prague and produced by ADVACAM s.r.o. company can be also integrated into such monitoring network.

Example of the radiation monitoring network based on the first version of **MINIPIX** is operated in ISS (International Space Station). This network was installed by common effort of NASA, University of Houston and IEAP CTU in Prague. Devices and software was developed by IEAP CTU in Prague.

Main Features

- Readout chip type Timepix
- Pixel size 55 x 55 μm
- Sensor resolution 256 x 256 pixels
- Dynamic range in one frame 11 082
- Dark current none
- Interface USB 2.0 (Full-Speed)
- Maximum frame rate 55 fps
- Dimensions 88.9 x 21 x 10 mm
- Weight 30 g

¹ **MINIPIX** is not certified dosimetric device. It serves as the first level indicator and monitor of radiation fields allowing identification of a radiation type. Radiation protection of people cannot be based on measurements of **MINIPIX**.

² Dynamic range of final picture is theoretically unlimited; the only limiting factor is exposure time.



Device parameters

Operating conditions

Symbol	Parameter	Value	Units	Comment
TA	Ambient Temperature Range	0-50	°C	
Φ	Humidity	<80	%	Not condensing
	Altitude*	<2000	m	Above sea level
IP	IP rating	IP40		With cover

*for use in vacuum chamber, operate only with air pressure lower than 10^{-3} Pa

Location: Intended for indoor use, dust free.

Electrical Specification

T_A = 25°C, USB voltage V_{CC} = 4.8V

Symbol	Parameter	Min	Typ	Max	Units	Comment
V _{CC}	Supply Voltage	4.0	5.0	5.5	V	Comply with USB 2.0
I _{CC2}	Chip active			500	mA	Comply with USB 2.0
P1	Power Dissipation			2.5	W	
Bias Voltage Source for Sensor Diode						
V _{BIAS}	Bias Voltage	3		200	V	

Performance characteristics of Timepix

Symbol	Parameter	Min	Typ	Max	Units	Comment
f	Frame-rate			55	fps	with USB 2.0 Host
T _{READ}	Frame Readout Time ³		19		ms	

³ During Readout time (or Dead time), no charge is collected from the sensor.



Sensor parameters

T_A = 25°C

Symbol	Parameter	Si			Units	Comment
		100	300	500		
	Thickness	100	300	500	μm	
σ	Energy resolution of energy discrimination threshold (σ @ 23 keV)	0.5			keV	
σ	Energy resolution of energy discrimination threshold (σ @ 60 keV)	0.6			keV	
σ	Energy resolution in full spectral mode (σ @ 23 keV)	0.7			keV	
σ	Energy resolution in full spectral mode (σ @ 60 keV)	1.0			keV	
	Typical detectable energy range for X-rays ⁴	5 to 60			keV	See chart below
	Pixel size	55			μm	

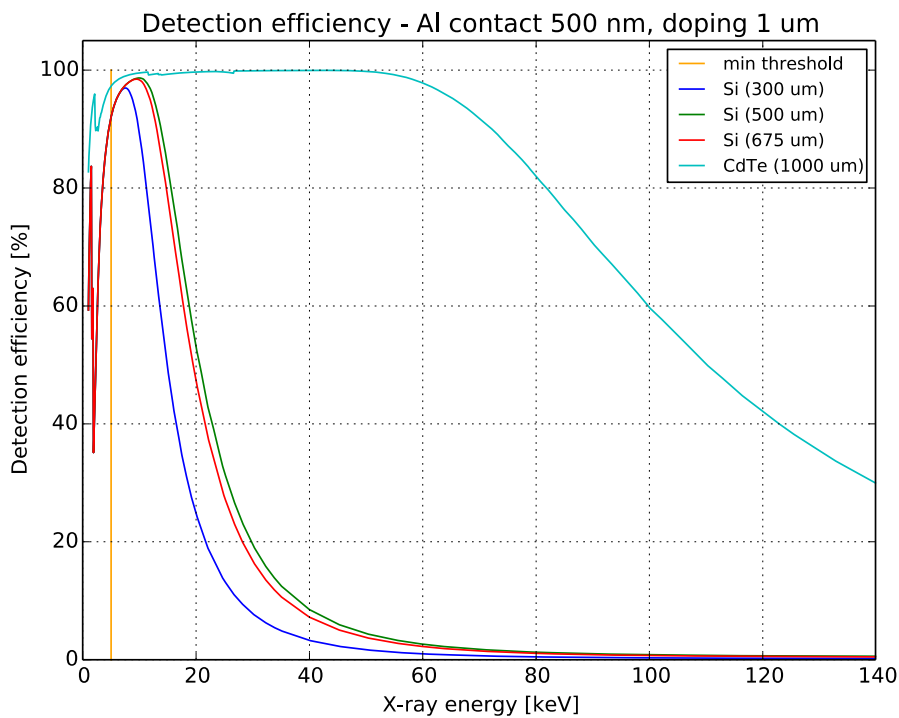

Modes of readout chip operation

Type	Mode	Precision	Description
Frame (reading all pixels)	Event	13bit/frame	1 output image: Number of Events per pixel
	ToT	13bit/frame	1 output image: Sum of all Energies deposited in given pixel(Time Over Threshold)
	ToA	13bit/frame	1 output image: Time of arrival of first event in given pixel



Device description



USB connector

USB type A, Standard USB 2.0 Full-Speed.

Certificates

MINIPIX has been tested by certification authority (Electrotechnical testing institute EZÚ) according to following standards:

Standard number	Name
EN 61000-6-2:05	Electromagnetic compatibility (EMC) - Immunity standard for industrial environments
EN 61000-6-4:07+A1:11	Electromagnetic compatibility (EMC) - Emission standard for industrial environments

Mechanical dimensions

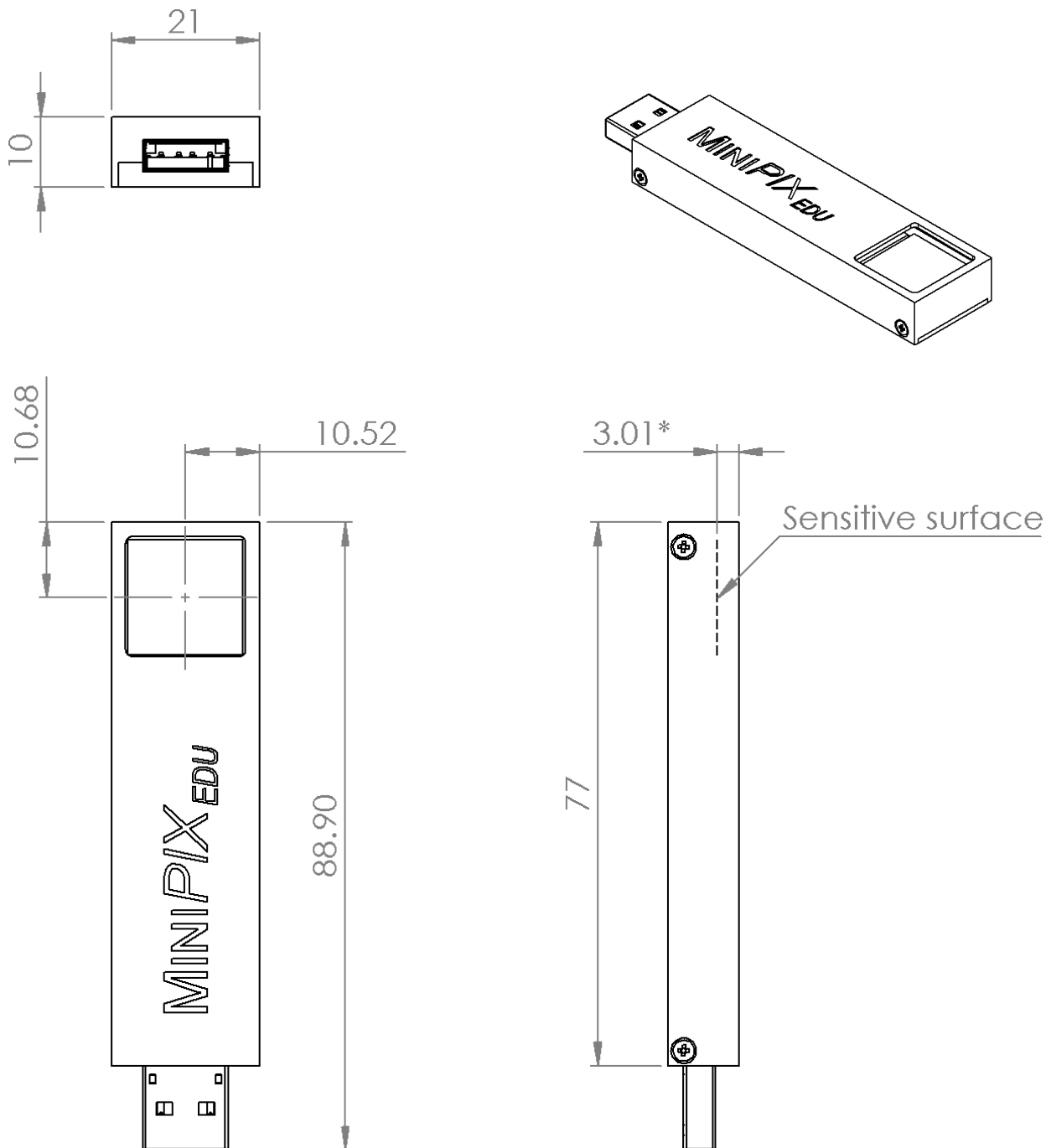

All dimensions are in mm.

* Sensitive surface distance from top of the box is for 300 μm sensor thickness.

Extreme care must be taken when removing protecting cover and handling the **MINIPIX** without the protecting cover. Warranty does not apply to mechanical damage of the sensor and wirebonds.



Model Number Codes

Example:

MNX TXE - X P 3 181116

Device name:

MNX – MiniPIX

Device modification:

TXE – Timepix Edu

Sensor type:

P – Planar silicon

Sensor thickness:

- 1 – 100 μm
- 3 – 300 μm
- 5 – 500 μm

Device version date:

YY MM DD

Release history

Date	Changes



Warning

Do not touch sensor surface!

Instructions for safe use

To avoid malfunction or damage to your **MINIPIX** please observe the following:

- Do not expose to water or moisture.
- Do not disassemble. Wire-bonding connection may be irreversibly damaged.
- Do not insert any object into the sensor window.
- Maximum USB cable length is 3m
- The protection provided by this product may be impaired if it is used in a manner not described in this document

Disposal:



Do not dispose these instruments as unsorted municipal waste. Please use separate collection facility to contact the supplier from which the instrument was purchased. Please make sure discarded electrical waste is properly recycled to reduce environment impact

Copyright

ADVACAM s.r.o.

U Pergamenky 1145/12

170 00 Praha

Czech Republic

Tel: +420 603 444 112

Email:

info@advacam.com

www.advacam.com

